

Low-Noise Amplifier Series



APPLICATION

The Comtech EF Data (CEFD) Low-Noise Amplifier (LNA) series includes LNAs and redundant LNA systems (C-, X- or Ku-Band). They meet or exceed system requirements for commercial geosynchronous satellites worldwide. Their compact design and rugged construction make them ideal for transportable applications and severe environments. They have a comprehensive set of options to accommodate systems ranging from Very Small Amplifier Terminal (VSATs) to major earth stations.

The redundant LNA systems include primary and backup LNAs and an automatic switching controller. In case of primary LNA failure, fast automatic switchover to the backup LNA minimizes "down" time.

TECHNOLOGY

The amplifiers incorporate both HEMT devices for low-noise temperature performance and GaAs FET devices for low intermodulation. The units use surface mounted components for robotic manufacturing techniques, thereby insuring maximum product consistency and enhanced reliability. XLNA includes integrated filtering to address adjacent power issues peculiar to demanding X-Band terminals

RELIABILITY

The amplifier series utilizes proprietary circuitry and high-quality components to achieve an MTBF in excess of 160,000 hours. Each unit is subjected to a 72-hour burn-in and temperature cycled from -40 to 140°F (-40 to +60°C).

CONSTRUCTION

The LNAs are housed in waterproof enclosures with small profiles to better accommodate redundancy configurations. The enclosures also provide a pressurizable, integral waveguide flange.

SUBSYSTEMS

1+1 (one backup for one primary) and 1+2 (one backup for two primary) redundant LNA systems are available, complete with mounting plate, brackets and indoor Redundancy Controller/Power Supply (transmit reject filters, cables and other integration materials are offered as required).

SPECIFICATIONS

Frequency	
CLNA & REDCLNA	3.4 to 4.2 GHz 3.625 to 4.2 GHz 3.625 to 4.8 GHz 4.5 to 4.8 GHz
XLNA & REDXLNA	7.25 to 7.75 GHz
KLNA & REDKLNA	10.95 to 12.75 GHz
Noise Temperature	
CLNA	30, 35, 40, 45 K
XLNA	40, 45 K
KLNA	65, 70, 80, 85 K
Gain	50, 60 dB
Overall Stability (Over Temp. & Frequency)	
CLNA	± .75 dB from 3.625 to 4.2 GHz ± 1 dB from 3.4 to 4.2 GHz 0.40 dB p-p over 40 MHz
REDCLNA	± 1.5 dB over Full Band typical 0.50 dB p-p over 40 MHz typical
XLNA	± 1.5 dB over Full Band typical 0.50 dB p-p over 40 MHz typical
REDXLNA	± 2 dB over Full Band typical 1 dB p-p over 40 MHz typical
KLNA	± 1.5 dB over Full Band 0.75 dB p-p over 40 MHz
REDKLNA	± 2 dB over Full Band typical 1 dB p-p over 40 MHz typical
Level @ 1 dB Comp.	+10 dBm, (20 dBm opt. for XLNA)
Third Order Intercept	+20 dBm (+30 dBm opt. for XLNA)
AM-PM Conversion	0.05°/dB @ -5 dBm
Linear Group Delay	0.01 ns/MHz (XLNA - ± .05 ns/MHz)
Parabolic Group Delay	0.001 ns/MHz ² (XLNA - ± .005 ns/MHz ²)
Ripple	0.1 ns p-p (XLNA - ± 1 ns p-p)
Input/Output VSWR	1.25:1 Maximum
Input Waveguide	
CLNA & REDCLNA	CPR229
XLNA & REDXLNA	CPR112
KLNA & REDKLNA	WR75
Output Connector	Type N Standard, Optional SMA
Operating Temp.	-40 to 140°F (-40 to +60°C)
Input Power	+12 to +24 VDC @ 120 mA
Power Connector	Coaxial or PTA02A-9-4P

Low-Noise Amplifier Series

System Diagrams

1:1 Redundant LNA System Block Diagram

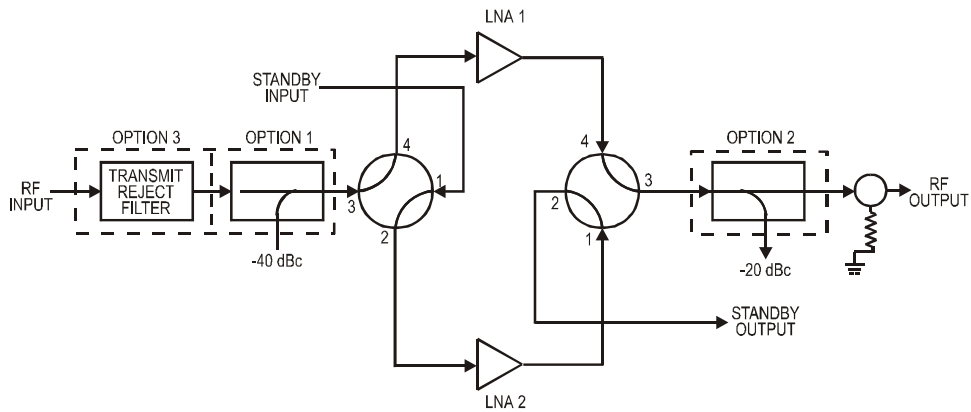

1:2 Redundant LNA System Block Diagram

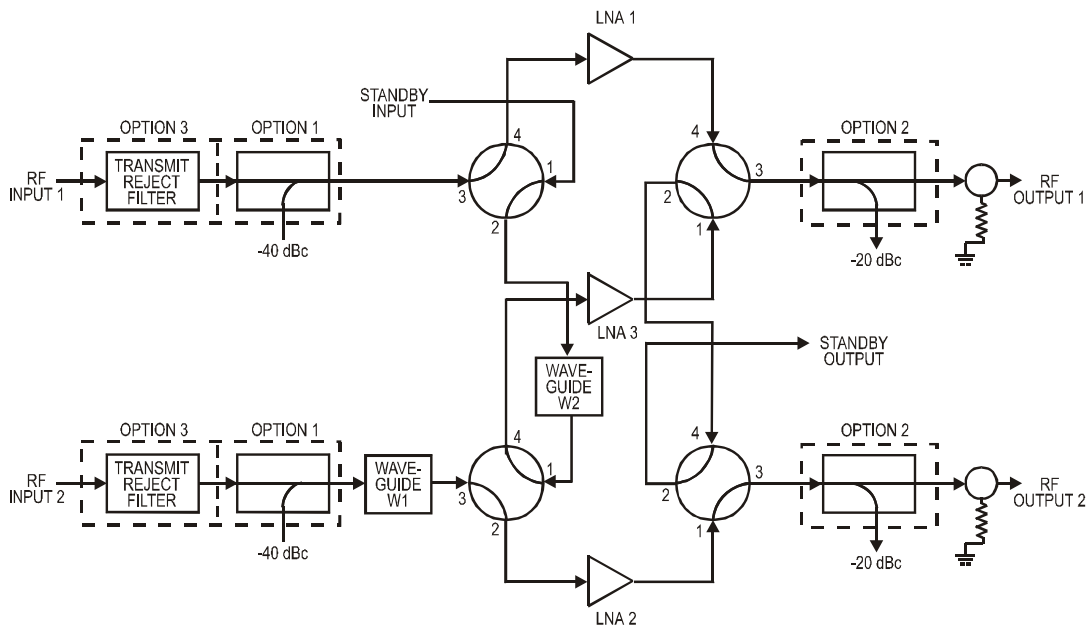

Typical system noise temperature calculation

1:1 Redundant LNA System

$$T_{\text{system}} = T_{\text{LNA}} + T_{\text{SWITCH}} + T_{\text{OPTION 3}} + T_{\text{OPTION 1}}$$

1:2 Redundant LNA System

RF input 1:LNA on-line signal path

$$T_{\text{system}} = T_{\text{LNA}} + T_{\text{SWITCH}} + T_{\text{OPTION 3}} + T_{\text{OPTION 1}}$$

RF input 1:LNA 3 on-line signal path (LNA 1 standby)

$$T_{\text{system}} = T_{\text{LNA}} + 2 * T_{\text{SWITCH}} + T_{\text{W2}} + T_{\text{OPTION 3}} + T_{\text{OPTION 1}}$$

RF input 2:LNA 2 on-line signal path

$$T_{\text{system}} = T_{\text{LNA}} + T_{\text{W1}} + T_{\text{SWITCH}} + T_{\text{OPTION 3}} + T_{\text{OPTION 1}}$$

RF input 1:LNA 3 on-line signal path (LNA 2 standby)

$$T_{\text{system}} = T_{\text{LNA}} + 2 * T_{\text{SWITCH}} + T_{\text{W1}} + T_{\text{W2}} + T_{\text{OPTION 3}} + T_{\text{OPTION 1}}$$

Typical Noise Temperature in Kelvin at 23°C

Band (GHz)	3.62 – 4.205	3.4 – 4.2	10.7 – 12.75
	WR-229	WR-229	WR-75
T_{SWITCH}	1.5°	1.5°	3.5°
T_{W1}	1.5°	1.5°	4.0°
T_{W2}	1.5°	1.5°	4.0°
T_{OPTION1}	0.5°	0.5°	2.0°
T_{OPTION3}	2.4°	7.0°	7.0°

